

# Model Checking

CS60030 FORMAL SYSTEMS

PALLAB DASGUPTA,  
FNAE, FASc,  
A K Singh Distinguished Professor in AI,  
Dept of Computer Science & Engineering  
Indian Institute of Technology Kharagpur  
Email: pallab@cse.iitkgp.ac.in  
Web: <http://cse.iitkgp.ac.in/~pallab>



INDIAN INSTITUTE OF TECHNOLOGY KHARAGPUR



# Formal Property Verification

- What is *formal property verification*?
  - Verification of *formal properties*?
  - *Formal methods* for property verification?
- Both are important requirements
- **Broad Classification**
  - Dynamic property verification (DPV)
  - Static/Formal property verification (FPV)

# Dynamic Property Verification (DPV)

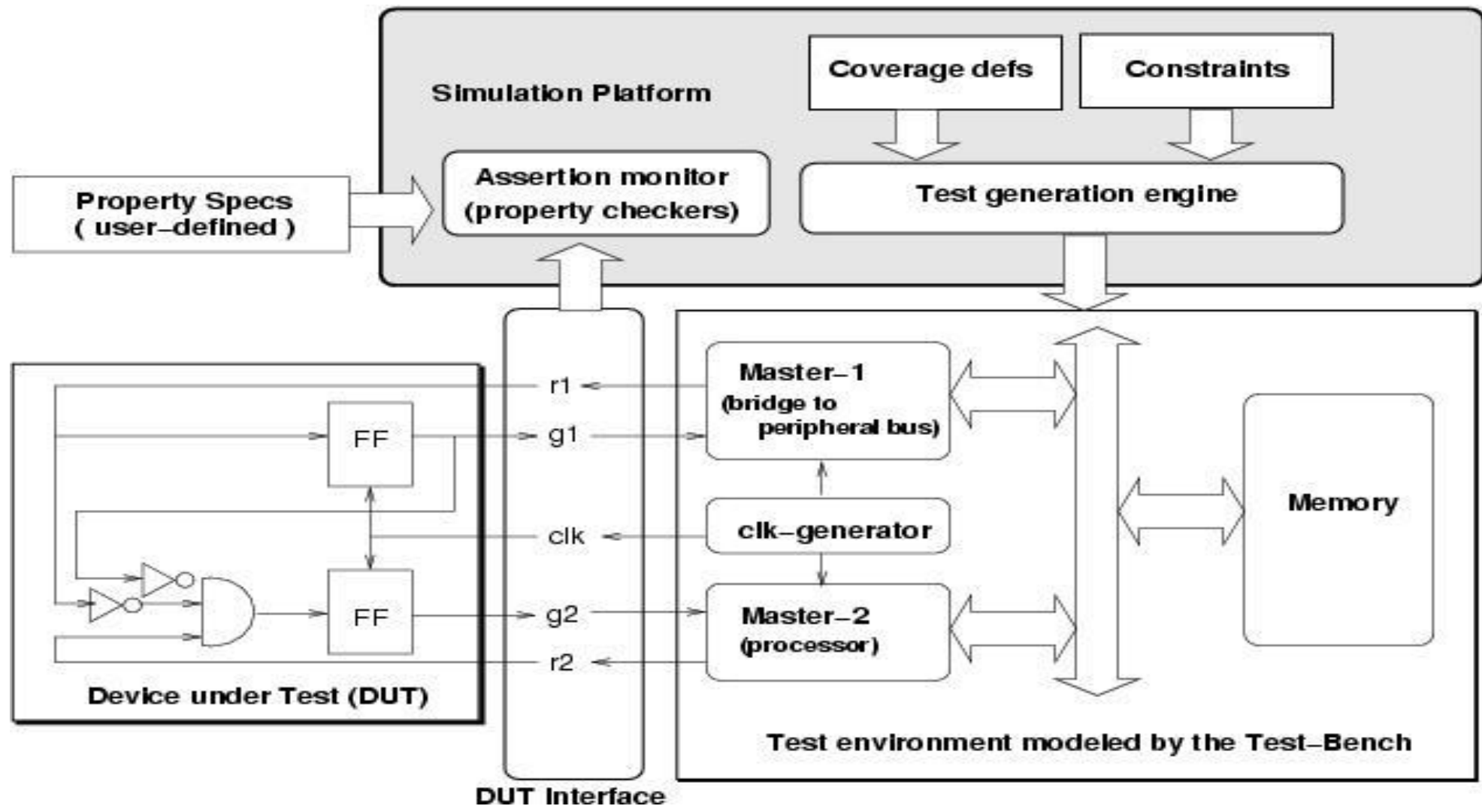

# Formal Property Verification (FPV)

Temporal Logics (Timed /  
Untimed, Linear Time /  
Branching Time): *LTL, CTL*

Early Languages: *Forspec*  
(Intel), *Sugar* (IBM), *Open Vera*  
*Assertions* (Synopsys)

Current IEEE Standards:  
*SystemVerilog Assertions*  
(SVA),

*Property Specification*  
*Language* (PSL)

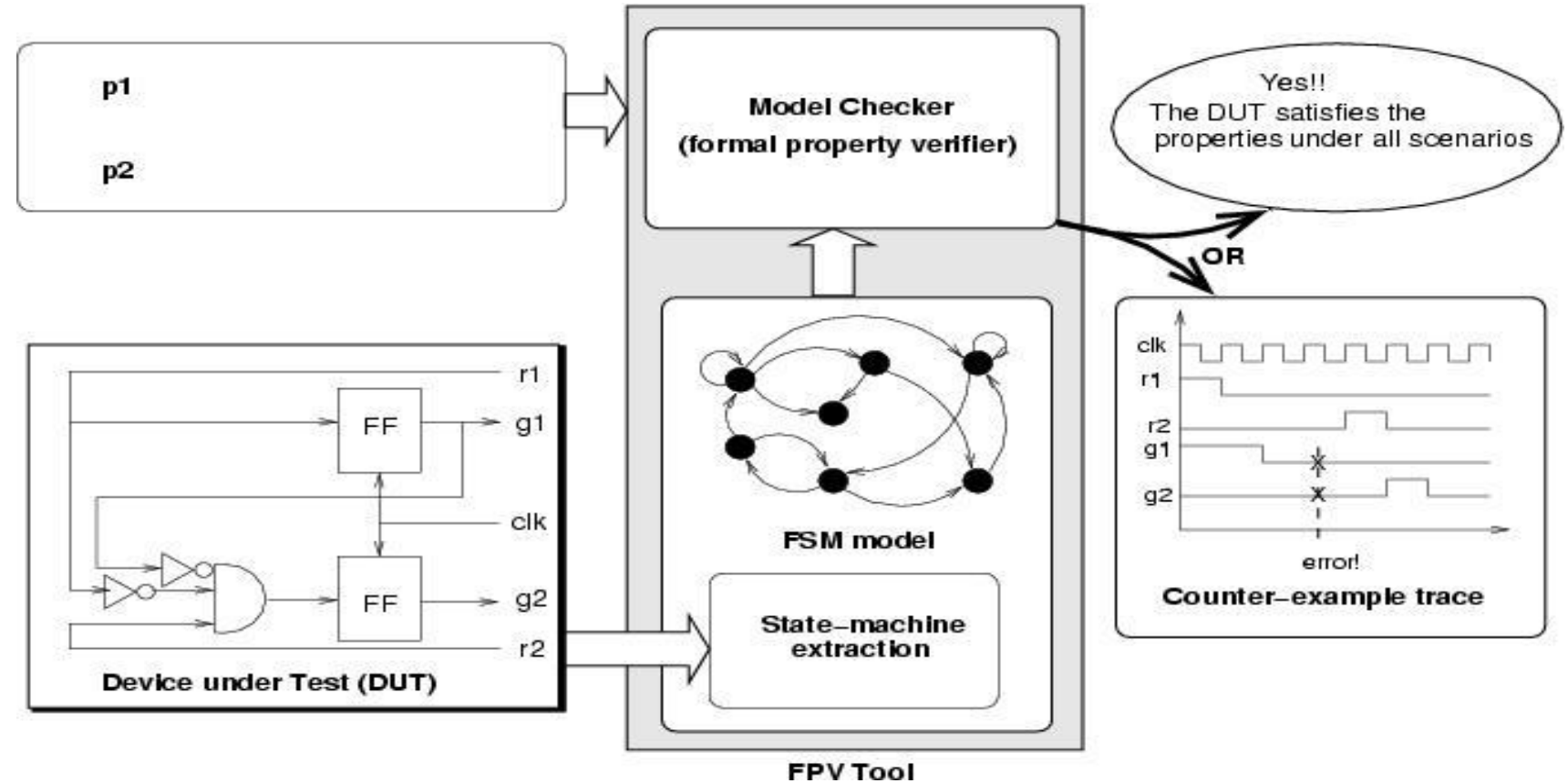

# Formal Property Verification

The formal method is called “*Model Checking*”

- The algorithm has two inputs
  - A finite state transition system (FSM) representing the implementation
  - A formal property representing the specification
- The algorithm checks whether the FSM “*models*” the property
  - This is an exhaustive search of the FSM to see whether it has any path / state that refutes the property.

# Transition Systems and Kripke Structures

A **transition system**  $TS$  is a tuple  $(S, Act, \rightarrow, I, AP, L)$  where

- $S$  is a set of **states**
- $Act$  is a set of **actions**
- $\rightarrow \subseteq S \times Act \times S$  is a **transition relation**
- $I \subseteq S$  is a set of **initial states**
- $AP$  is a set of **atomic propositions**
- $L : S \rightarrow 2^{AP}$  is a **labeling function**

$S$  and  $Act$  are either finite or countably infinite

A **Kripke Structure**  $TS$  is a tuple  $(S, \rightarrow, I, AP, L)$  where

- $S$  is a set of **states** (inputs are part of the state)
- $\rightarrow \subseteq S \times S$  is a **transition relation**
- $I \subseteq S$  is a set of **initial states**
- $AP$  is a set of **atomic propositions**
- $L : S \rightarrow 2^{AP}$  is a **labeling function**

$\rightarrow$  is a total relation, that is, every state has a next state (could be itself)

$S$  is finite

In this discussion we shall use the notion of Kripke structures

# Modeling Sequential Circuits as Kripke Structures

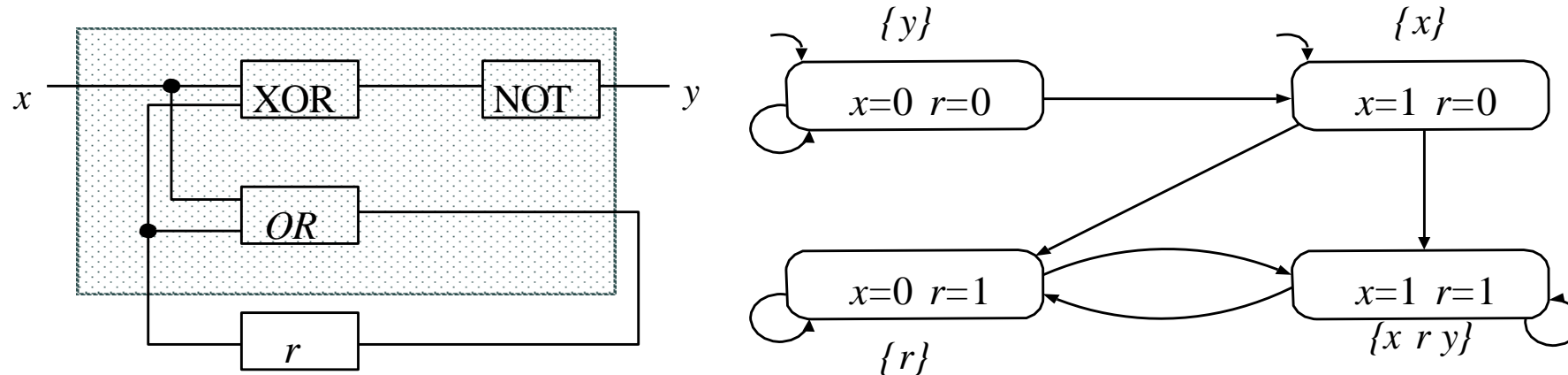

A simple hardware circuit with Input variable  $x$ , Output variable  $y$ , and Register  $r$

Output function  $\neg(x \oplus r)$  and register evaluation function  $x \vee r$

# Atomic Propositions

Consider two possible state-labelings:

- Let  $AP = \{ x, y, r \}$ 
  - $L((x = 0, r = 1)) = \{ r \}$  and  $L((x = 1, r = 1)) = \{ x, r, y \}$
  - $L((x = 0, r = 0)) = \{ y \}$  and  $L((x = 1, r = 0)) = \{ x \}$
  - property e.g., “once the register is one, it remains one”
- Let  $AP' = \{ x, y \}$  – the register evaluations are now “invisible”
  - $L((x = 0, r = 1)) = \emptyset$  and  $L((x = 1, r = 1)) = \{ x, y \}$
  - $L((x = 0, r = 0)) = \{ y \}$  and  $L((x = 1, r = 0)) = \{ x \}$
  - property e.g., “the output bit  $y$  is set infinitely often”

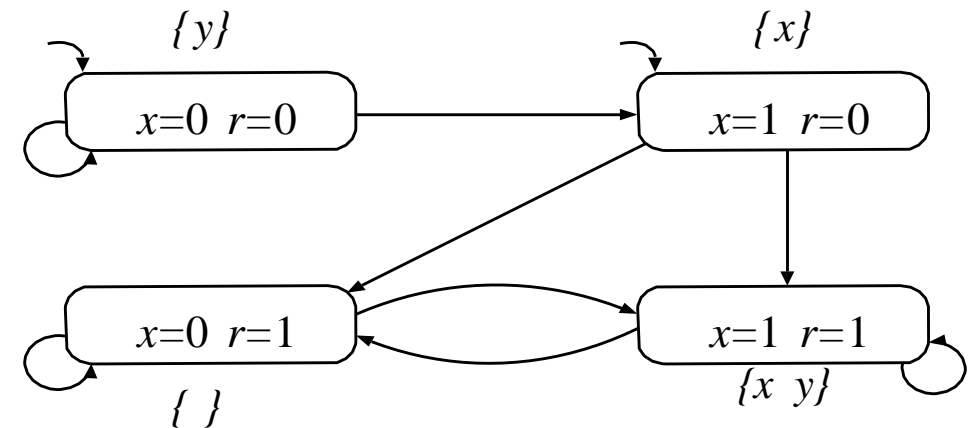
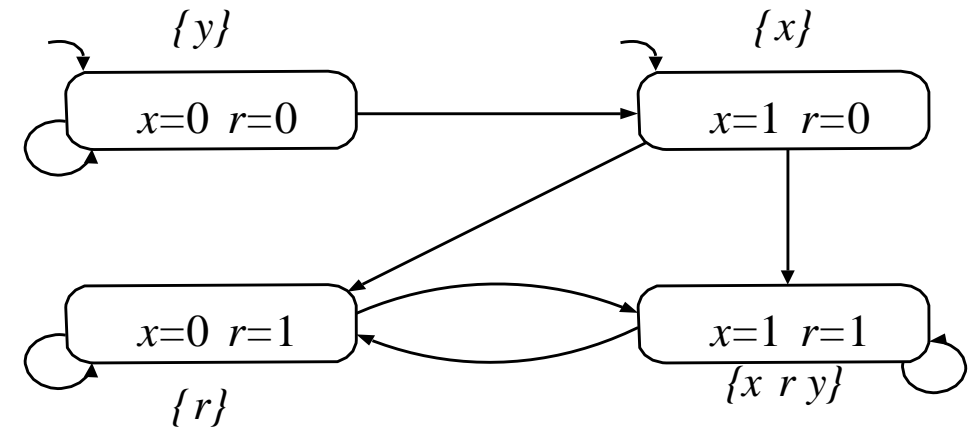



# Automata over Infinite Words

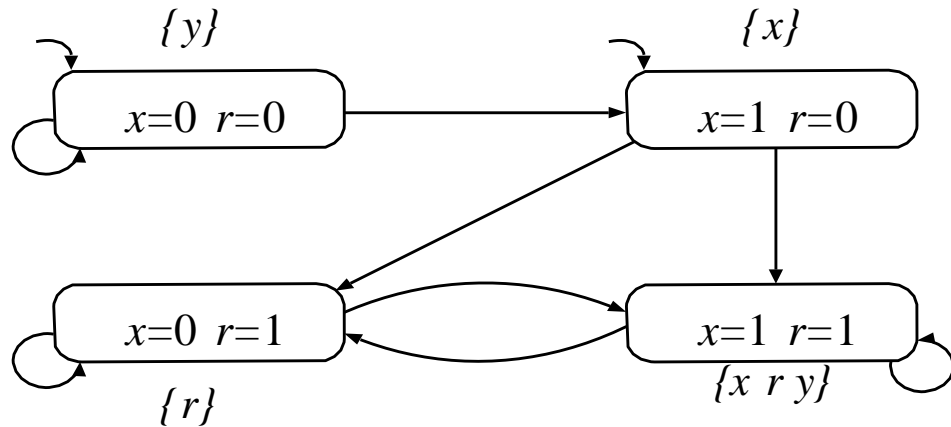

- A run of this state machine is an infinite sequence of states.
  - If we observe only the state labels, then each state is viewed as a combination of labels (note that two states can have same labels)

## Runs of the transition system:

$$\Sigma = \{ \{\}, \{x\}, \{y\}, \{r\}, \{x y\}, \{x r\}, \{r y\}, \{x r y\} \} = 2^{AP}$$

Each run of the system belongs to  $(2^{AP})^\omega$  that is, the set of infinite words over  $\Sigma$

$$\text{Runs(TS)} \subseteq (2^{AP})^\omega$$

## Runs of the formal property:

Linear time properties are also defined over  $\Sigma = 2^{AP}$

Each run in  $(2^{AP})^\omega$  either satisfies a given formal property  $\varphi$  or is a counterexample

$$\text{Runs}(\varphi) \subseteq (2^{AP})^\omega$$

$\text{TS} \models \varphi$  ( read as TS models  $\varphi$  ) iff  $\text{Runs(TS)} \subseteq \text{Runs}(\varphi)$

# Model Checking Linear Time Properties

- Linear Temporal Logic (LTL) captures an expressive subset of Omega Regular Languages

- SVA is derived from LTL

- Given a LTL property,  $\varphi$ , to determine whether  $TS \models \varphi$  we do the following:

- Since  $TS \models \varphi$  iff  $\text{Runs}(TS) \subseteq \text{Runs}(\varphi)$ , it follows that

$$\text{Runs}(TS) \cap [(2^{AP})^\omega - \text{Runs}(\varphi)] = \emptyset$$

- We create an automaton,  $B_{\neg\varphi}$ , which accepts runs satisfying  $\neg\varphi$ , that is, runs in  $(2^{AP})^\omega - \text{Runs}(\varphi)$
  - We compute the product of TS with  $B_{\neg\varphi}$  and check whether the product has any accepting run.
    - If not then  $TS \models \varphi$ .
    - Otherwise, the accepting run is a counter-example trace.

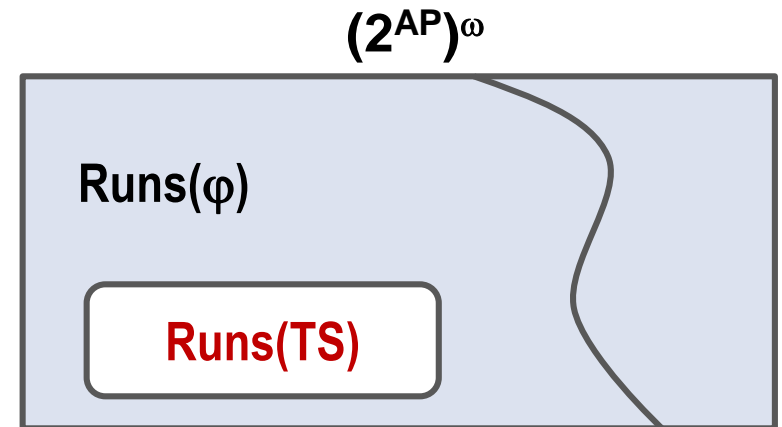

# Nondeterministic Büchi automata

- NFA (and DFA) are incapable of accepting infinite words
- A nondeterministic **Büchi** automaton (NBA)  $A$  is a tuple  $(Q, \Sigma, \delta, Q_0, F)$  where:
  - $Q$  is a finite set of states with  $Q_0 \subseteq Q$  a set of initial states
  - $\Sigma$  is an **alphabet**
  - $\delta: Q \times \Sigma \rightarrow 2^Q$  is a **transition function**
  - $F \subseteq Q$  is a set of **accept** (or: final) states
- NBAs are structurally similar to NFAs.
- But they have separate *acceptance criteria*
  - An NFA accepts its (finite) input if some run of the NFA reaches an accept state at the end of the input
  - A Büchi automaton accepts its infinite length input if **at least one of the accept states is visited infinitely often**

# Linear Time Properties can be converted to NBA

$a \cup b$

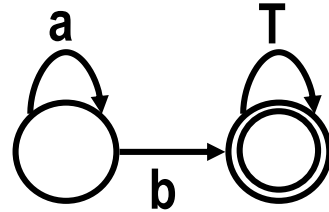

$p \cup (q \cup r)$

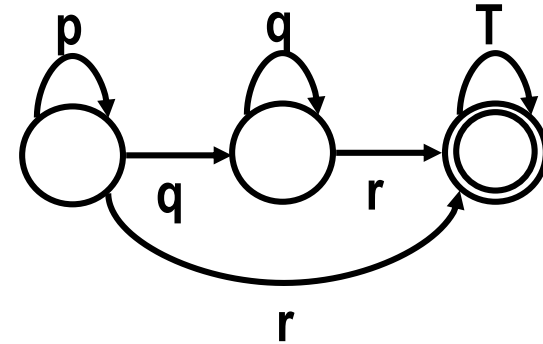

$GF(p \wedge Xp)$

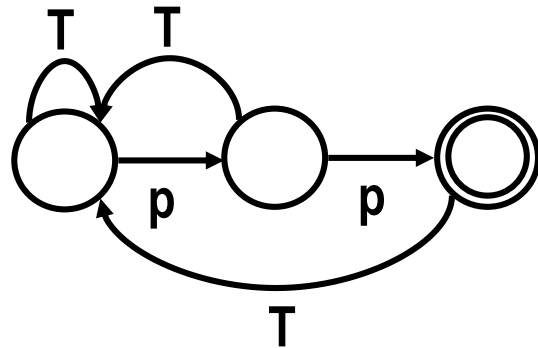

Here the Büchi acceptance criteria ensures that  $p \wedge Xp$  is satisfied infinitely often.

DFAs and NFAs are equally powerful, and therefore many algorithms convert a NFA to a DFA before product construction.

Non-deterministic Büchi automata are strictly more powerful than deterministic Büchi automata. Therefore we do not attempt to convert a NBA to a DBA.

# LTL Model Checking – An Overview

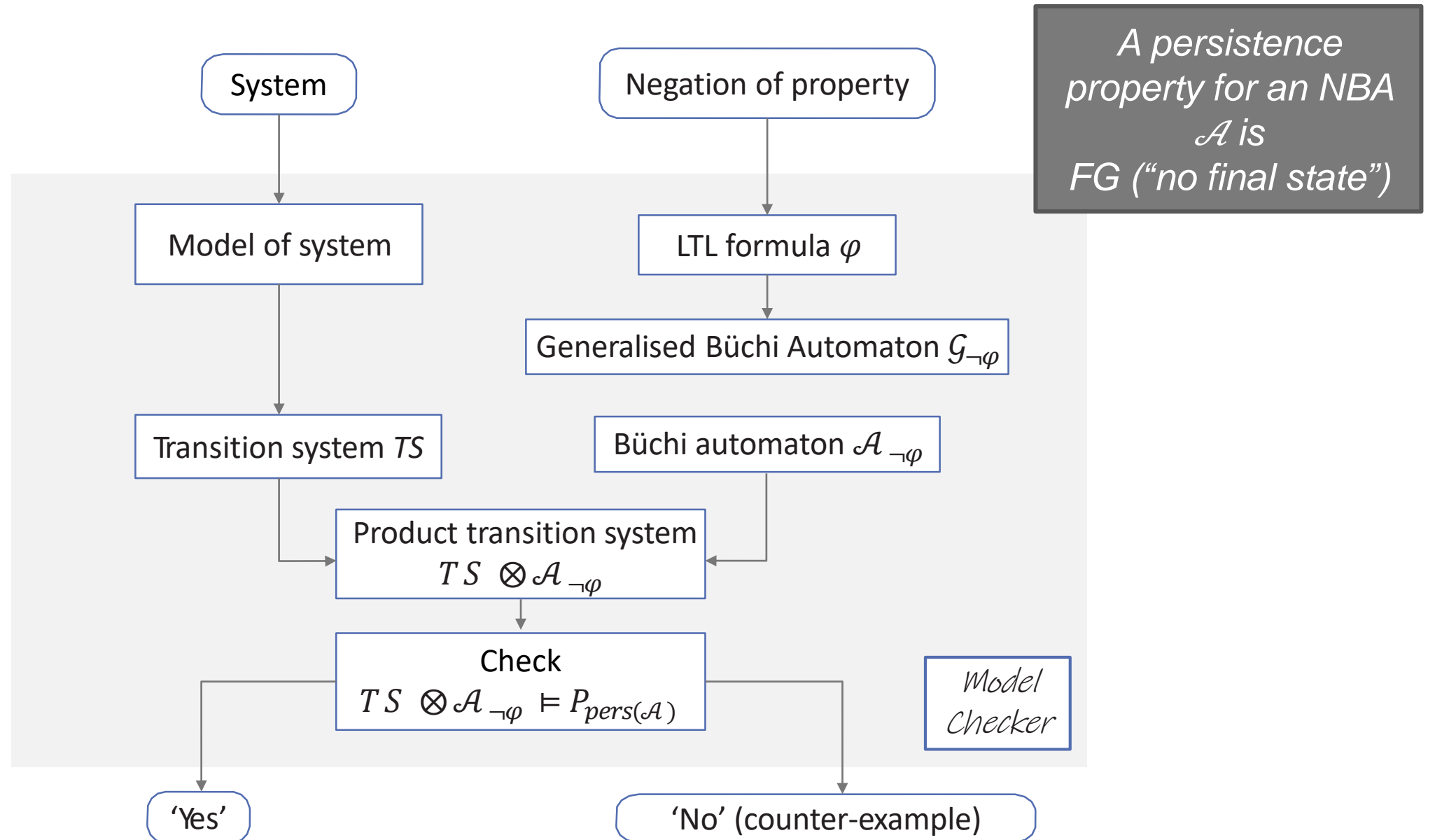

# Our running example: *Priority Arbiter*

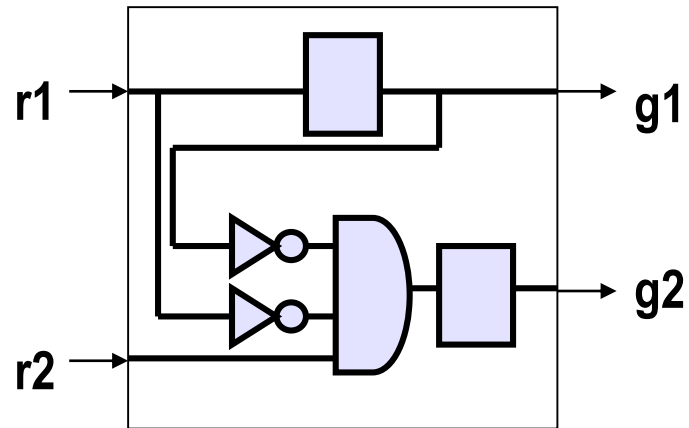

Design-under-test (DUT)

## Specification: Formal Property

- One of the grant lines is always asserted
- In Linear Temporal Logic:  $G( g1 \vee g2 )$

We wish to check whether:  $TS(DUT) \models G( g1 \vee g2 )$

# The Kripke Structure: TS(DUT)

## Transition Relation:

$$g'_1 \Leftrightarrow r_1$$

$$g'_2 \Leftrightarrow \neg r_1 \wedge r_2 \wedge \neg g_1$$

## Initial State:

$$r_1=0, r_2=0, g_1=0, g_2=1$$

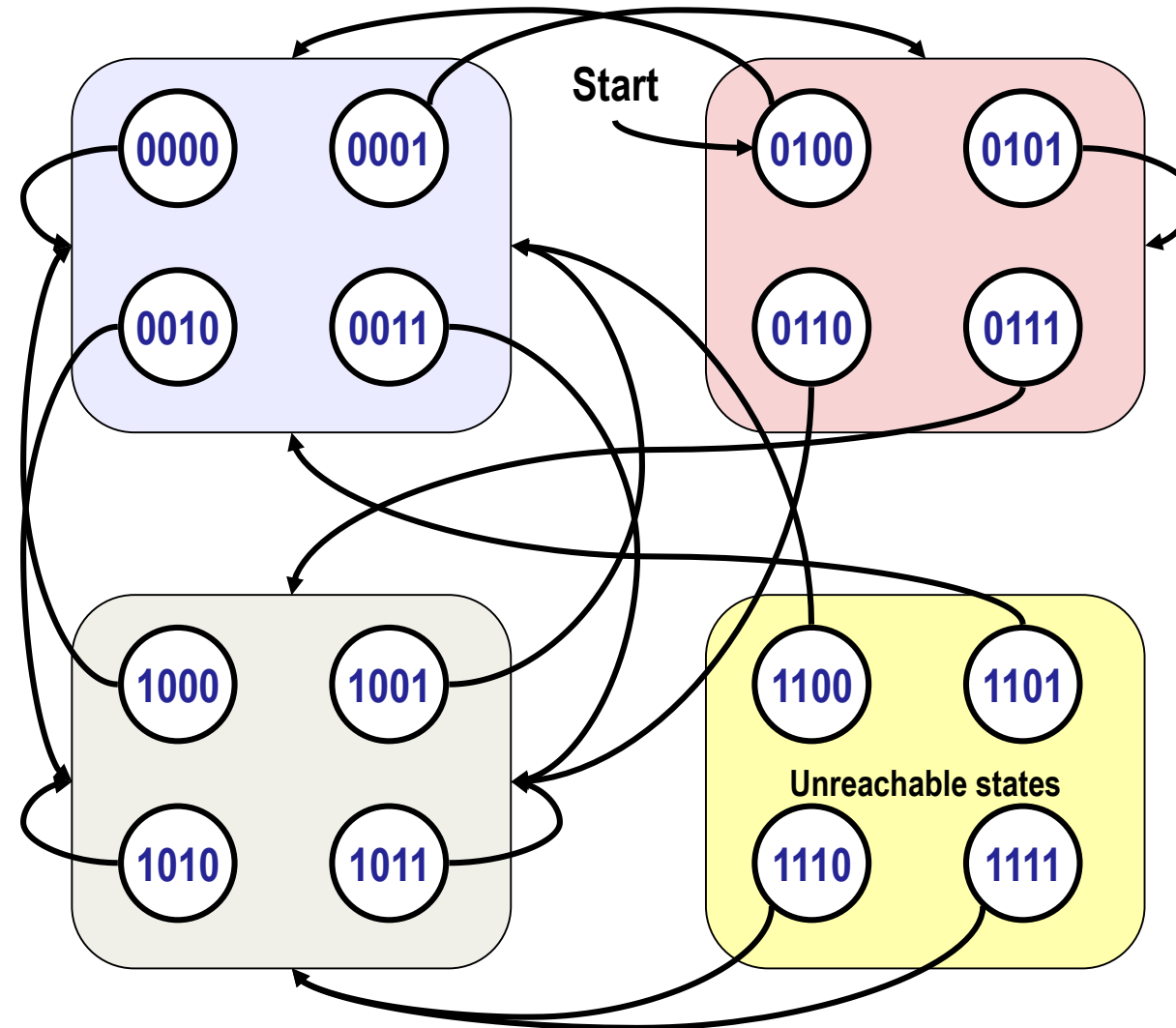
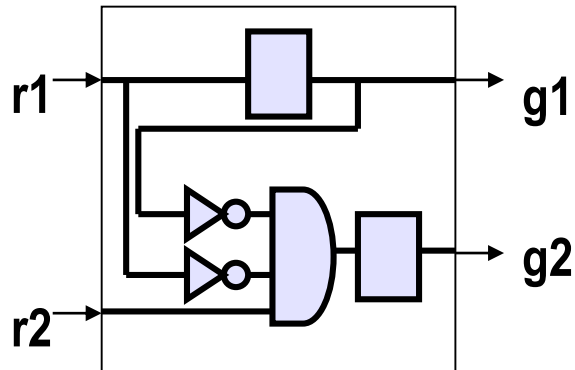

PS $g_1g_2$	I/P $r_1r_2$	NS $g'_1g'_2$	Next I/P
00	00	00	xx
00	01	01	xx
00	10	10	xx
00	11	10	xx
01	00	00	xx
01	01	01	xx
01	10	10	xx
01	11	10	xx
10	00	00	xx
10	01	00	xx
10	10	10	xx
10	11	10	xx
11	00	00	xx
11	01	00	xx
11	10	10	xx
11	11	10	xx

**This is only for demonstration !!**

We will never create this explicitly, but encode it in SAT / BDD

# Now we handle the specification

Our property:  $\varphi = G[ g_1 \vee g_2 ]$

- Either of the grant lines is always active

We will create the automaton,  $\mathcal{A}$ , for  $\neg\varphi$

- $\neg\varphi = F[ \neg g_1 \wedge \neg g_2 ]$
- Sometime both grant lines will be inactive

We will then search for a common run between this automaton and the TS(DUT) from the implementation



# Intuitive steps towards creating the automaton for the property

- Let us consider our property  $F(\neg g_1 \wedge \neg g_2)$  // *Eventually q is true*
- Using  $q$  as a short form for  $\neg g_1 \wedge \neg g_2$  we can rewrite it as:

$$Fq = q \vee XFq \quad // \textit{Either } q \textit{ is true now or } Fq \textit{ is true in the next state}$$

- Therefore we can classify the states in a run into the following types:
  - States that satisfy  $q$
  - States that do not satisfy  $q$  but satisfy  $XFq$
  - States that do not satisfy  $q$  and do not satisfy  $XFq$
  - The first two types are labeled by  $Fq$

# The automaton for our property

Our property:  $Fq$  where  $q = \neg g_1 \wedge \neg g_2$

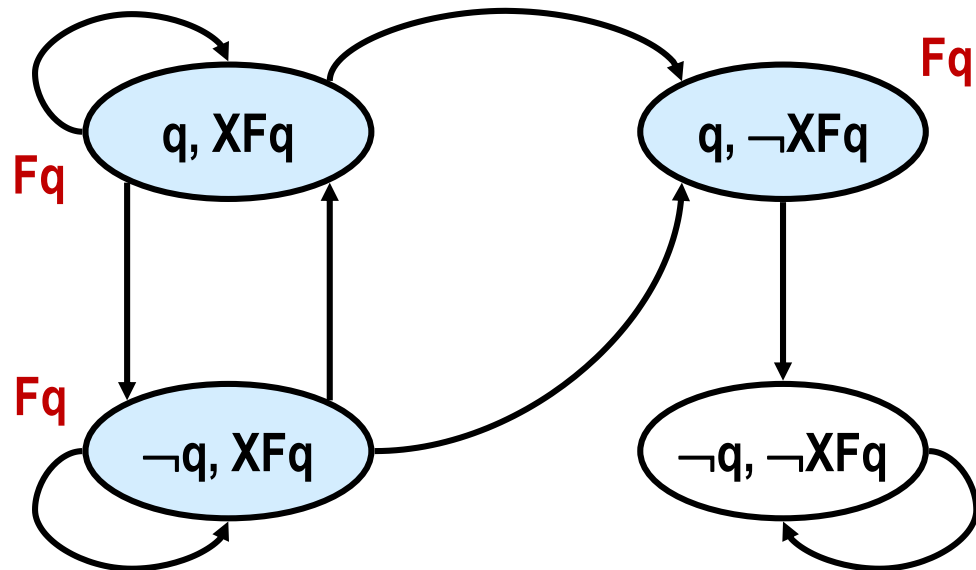

- States that satisfy  $q$  and states that do not satisfy  $q$  but satisfy  $XFq$  are labeled with  $Fq$
- We add the following edges:
  - From states satisfying  $XFq$  to states labeled with  $Fq$
  - From states satisfying  $\neg XFq$  to states satisfying  $\neg q$
- But the self loop in the state labeled  $\{\neg q, XFq\}$  is problematic
  - It allows the satisfaction of  $q$  to be postponed forever, in which case  $Fq$  does not hold

# The Büchi Automaton

Our property:  $Fq$  where  $q = \neg g_1 \wedge \neg g_2$

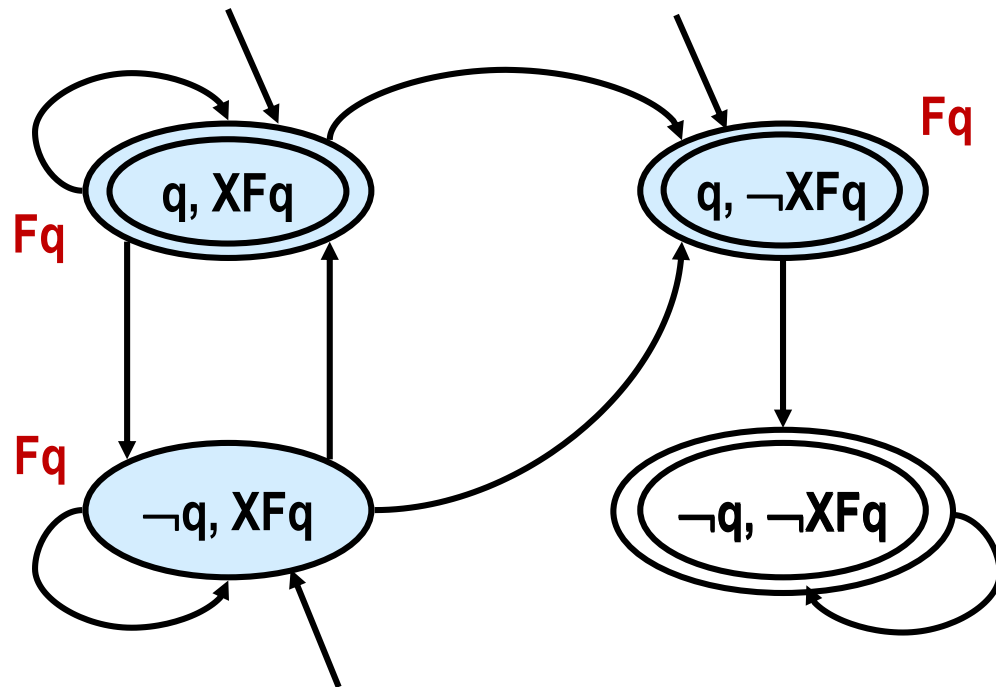

- The self loop in the state labeled  $\{\neg q, XFq\}$  is problematic
  - It allows the satisfaction of  $q$  to be postponed forever, in which case  $Fq$  does not hold
- By defining the remaining three states as **accept states**, we force the accepting runs to come out of the state labeled  $\{\neg q, XFq\}$ 
  - Recall that the **Büchi acceptance criterion** states that **accept states must be visited infinitely often.**

# Is the product non-empty?

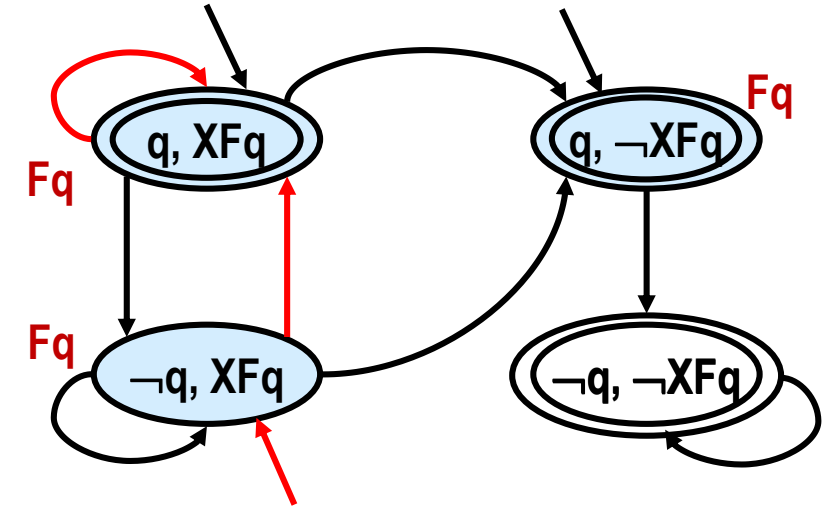
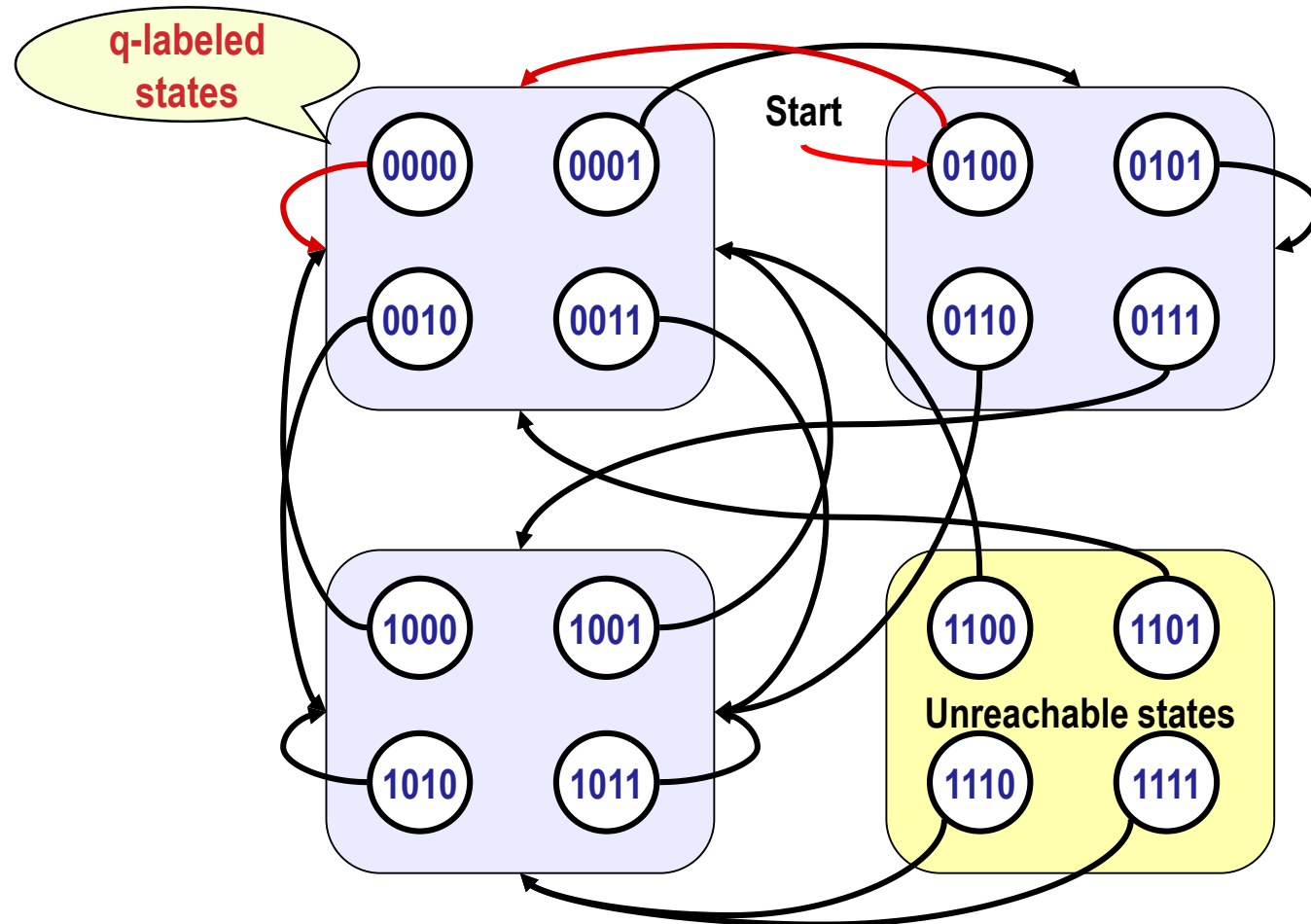

The common run is shown in red. Product is non-empty.

Conclusion:  $TS(DUT) \models G(g1 \vee g2)$  is not true. The counterexample is the run in red.

# Computational facts

- If a LTL property has  $k$  sub-formulas, then the number of states in its automaton may have  $O(2^k)$  states
  - Decomposing the property into a conjunction of smaller properties helps in containing the size of this automaton
  - It also helps the FPV tool to prune away parts of the implementation before making the emptiness check
- LTL model checking is PSPACE-complete, but linear in the size of the implementation
  - However, the main bottleneck is in the size of the implementation, which is why we use succinct representations.

# “Elementary” Sets for $\varphi$

- For an LTL-property  $\varphi$ , the set **closure**( $\varphi$ ) consists of:
  - All sub-formulas  $\psi$  of  $\varphi$  and their negation  $\neg\psi$ .

The set  $B \subseteq \text{closure}(\varphi)$  is **elementary** if:

1. **B is logically consistent** - if for all  $\varphi_1 \wedge \varphi_2, \psi \in \text{closure}(\varphi)$ :
  - $\varphi_1 \wedge \varphi_2 \in B \iff \varphi_1 \in B \text{ and } \varphi_2 \in B$
  - $\psi \in B \implies \neg\psi \notin B$
  - $\text{true} \in \text{closure}(\varphi) \implies \text{true} \in B$
2. **B is locally consistent** – if for all  $\varphi_1 \cup \varphi_2 \in \text{closure}(\varphi)$ :
  - $\varphi_2 \in B \implies \varphi_1 \cup \varphi_2 \in B$
  - $\varphi_1 \cup \varphi_2 \in B \text{ and } \varphi_2 \notin B \implies \varphi_1 \in B$
3. **B is maximal** – for all  $\psi \in \text{closure}(\varphi)$ :
  - $\psi \notin B \implies \neg\psi \in B$

# The GNBA for the LTL-property $\varphi$

- A Generalized NBA has multiple sets of accept states,  $F_1, \dots, F_k$  each of which must be visited infinitely often in an accepting run
- For the LTL-property  $\varphi$ , let  $\mathcal{G}_\varphi = (Q, 2^{AP}, \delta, Q_0, \mathcal{F})$ , where
  - $Q$  is the set of elementary sets of formulas  $B \subseteq \text{closure}(\varphi)$ .
    - $Q_0 = \{ B \in Q \mid \varphi \in B \}$
  - $\mathcal{F} = \{ \{ B \in Q \mid \varphi_1 \cup \varphi_2 \notin B \text{ or } \varphi_2 \in B \} \mid \varphi_1 \cup \varphi_2 \in \text{closure}(\varphi) \}$
  - The transition relation  $\delta: Q \times 2^{AP} \rightarrow Q$  is given by:
    - $\delta(B, B \cap AP)$  is the set of all elementary sets of formulas  $B'$  satisfying:
      - For every  $X\psi \in \text{closure}(\varphi)$  :  
 $X\psi \in B \Leftrightarrow \psi \in B'$
      - AND
      - For every  $\varphi_1 \cup \varphi_2 \in \text{closure}(\varphi)$ :  
 $\varphi_1 \cup \varphi_2 \in B \Leftrightarrow (\varphi_2 \in B \vee (\varphi_1 \in B \wedge \varphi_1 \cup \varphi_2 \in B'))$

# GNBA for $\varphi = \text{O}a$

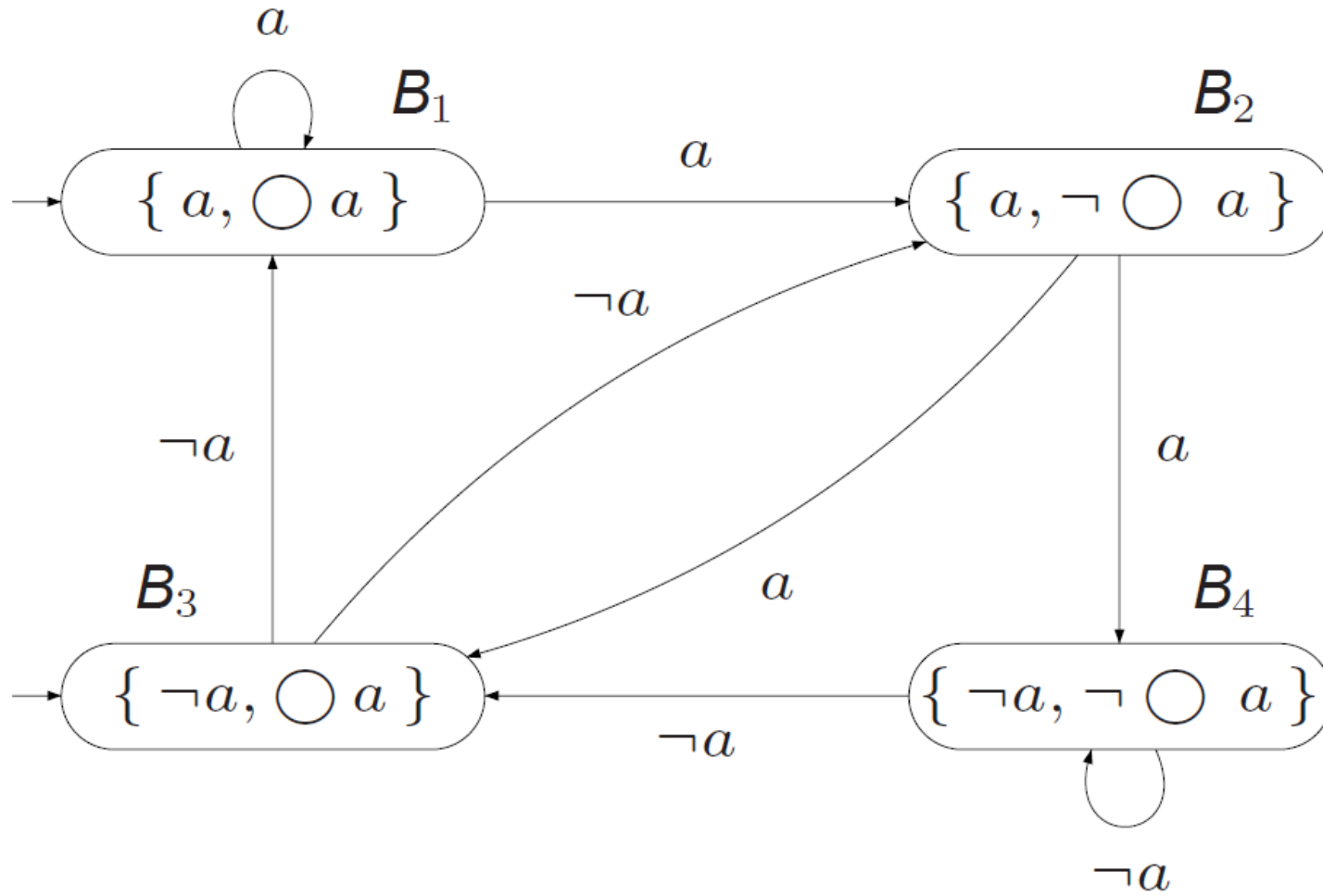



# GNBA for $\varphi = a \cup b$

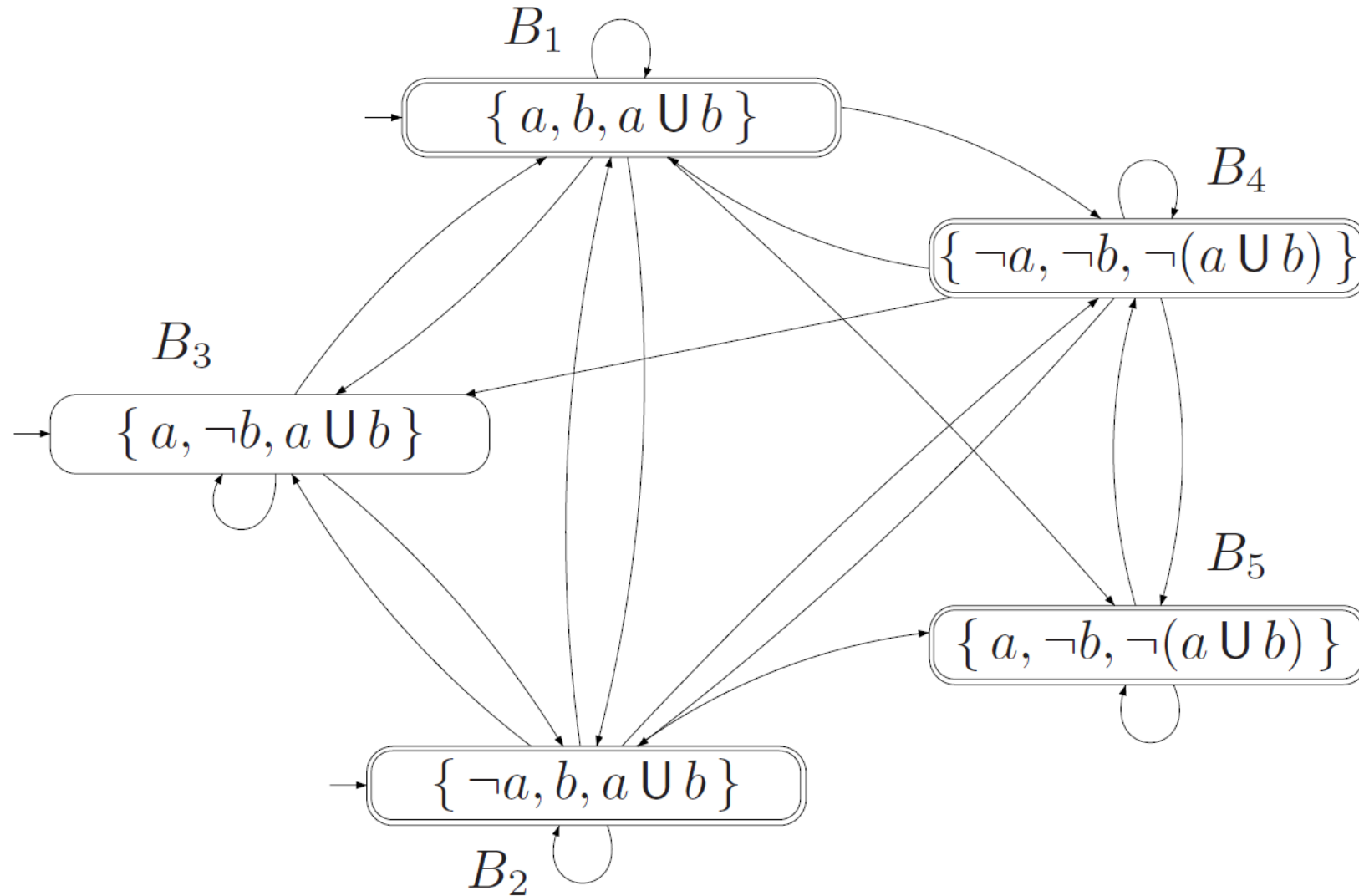

# Emptiness Check

- Emptiness check for a NFA is to find whether any accepting run exists
  - Can be decided by finding whether any accept state is reachable
  - We can do this using the symbolic reachability methods discussed earlier
- Emptiness check for a NBA is to find whether any accepting run exists using the **Büchi acceptance criterion**
  - Can be decided by finding whether any **strongly connected component** containing one or more accept states is reachable
  - Once we find the states in strongly connected components with accept states, we can use the symbolic reachability methods to find whether such components are reachable from the initial states
  - **How to find strongly connected components using symbolic search?**

# Exercises

- Let  $AP = \{a\}$  and  $\varphi = (a \wedge \bigcirc a) \cup \neg a$  an LTL formula over  $AP$ 
  - Compute all elementary sets with respect to  $\varphi$ . (*Hint: There are five elementary sets*)
  - Construct the generalized Büchi automaton (GNBA)  $\mathcal{G}_\varphi$  such that  $\mathcal{L}_\omega(\mathcal{G}_\varphi) = \text{Words}(\varphi)$

- We consider the LTL formula:

$$\varphi = G(a \Rightarrow (\neg b U (a \wedge b)))$$

over the set  $AP = \{a, b\}$  of atomic propositions and want to check  $TS \models \varphi$  with respect to the transition system on the right.

- Construct a NBA,  $A_{\neg\varphi}$ , for the negation of  $\varphi$ . You may do this intuitively. (*Hint: Four states suffice*)
- Construct  $TS \otimes A_{\neg\varphi}$
- Show how the product can be analyzed to determine whether  $TS \models \varphi$

$TS :$

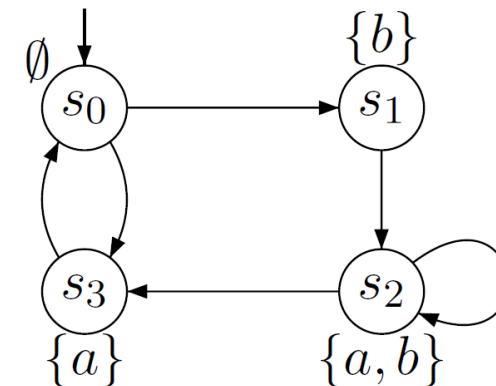

# CTL Model Checking

- Need only to show methodology for EX, EU, EG.
- Other modalities can be expressed in terms of EX, EU, EG.
  - $AFp = \neg EG \neg p$
  - $AGp = \neg EF \neg p$
  - $A(p \text{ U } q) = \neg E[\neg q \text{ U } (\neg p \wedge \neg q)] \wedge \neg EG \neg q$

# Example: EX p

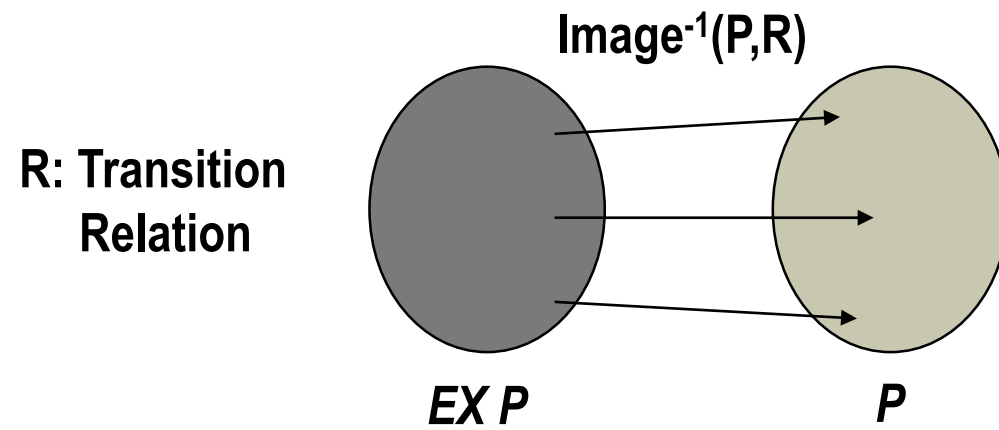

$$EXp = \{v \mid \exists v' (v, v') \in R \wedge p \in \mathcal{L}(v')\}$$

# Example: EF g

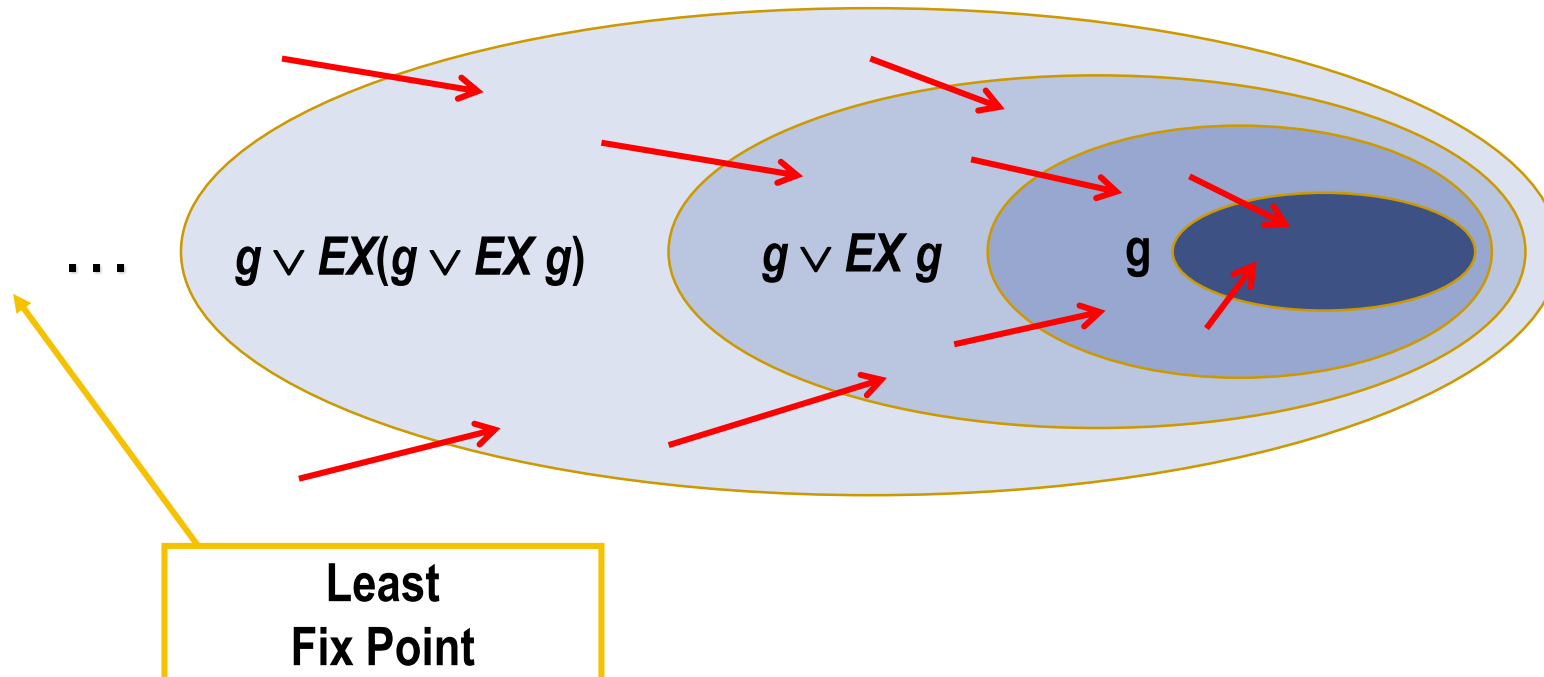

Given a model  $M = \langle AP, S, S_0, R, L \rangle$  and  $S_g$  the sets of states satisfying  $g$  in  $M$

procedure **CheckEF** ( $S_g$ )

$Q := \text{emptyset}; Q' := S_g;$

while  $Q \neq Q'$  do

$Q := Q';$

$Q' := Q \cup \{s \mid \exists s' [R(s,s') \wedge Q(s')]\}$

end while

$S_f := Q; \text{return}(S_f)$

# Example: EG g

EG g is calculated as

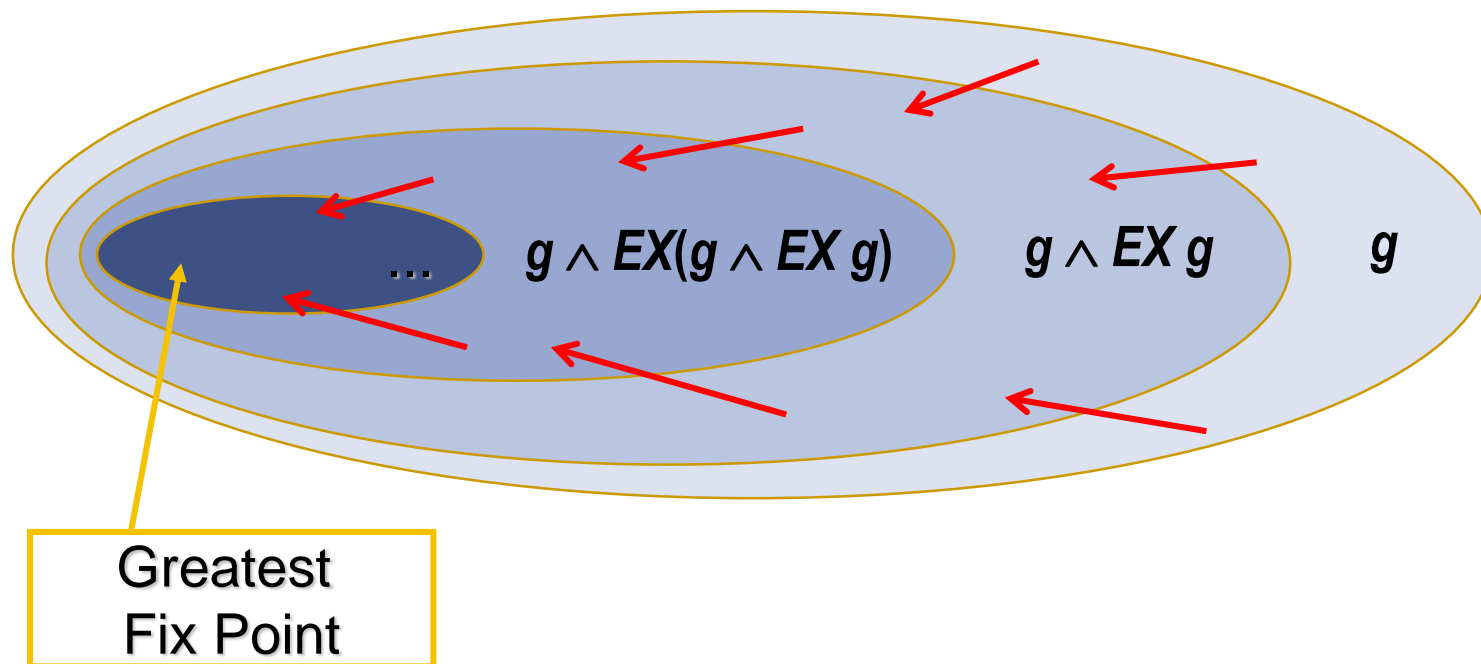

Given a model  $M = \langle AP, S, S_0, R, L \rangle$  and  $S_g$  the sets of states satisfying  $g$  in  $M$

procedure **CheckEG** ( $S_g$ )

$Q := S$  ;  $Q' := S_g$  ;

while  $Q \neq Q'$  do

$Q := Q'$  ;

$Q' := Q \cap \{ s \mid \exists s' [ R(s,s') \wedge Q(s') ] \}$

end while

$S_f := Q$  ; return( $S_f$ )

# Checking Nested Formulas

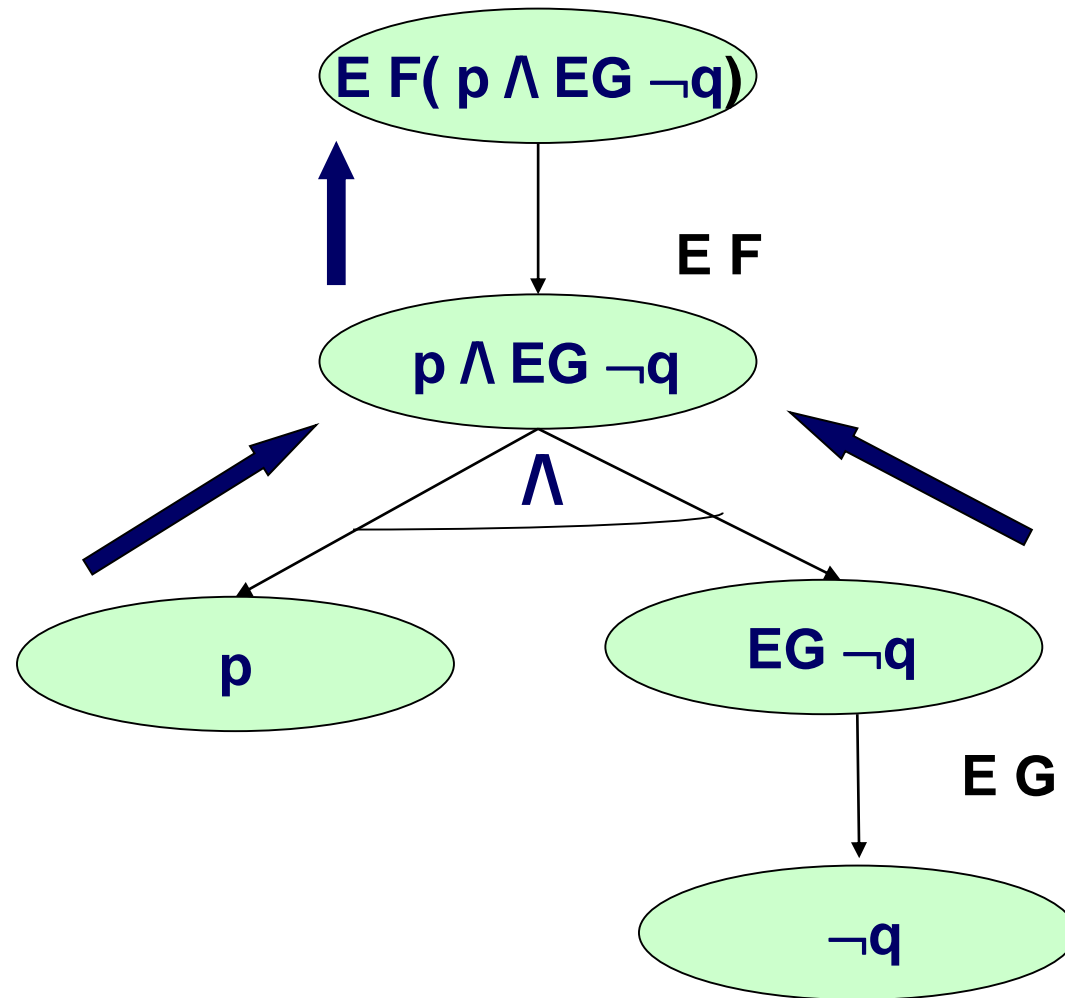

**Bottom Up**



# Checking Nested formulas

$EF(p \wedge EG \neg q)$

● p state

● q state

●  $\neg p \wedge \neg q$  state

$EF(p \wedge EG \neg q)$

